

G03 Mono-Block Series

Maximum Flow Rate: 11.7 l/min (3.1 gpm)

Maximum Pressure: 69 bar (1000 psi) for Metallic Pump Heads



WANNER
Hydra-Cell[®]
Seal-less Pump Technology



Mono-Block (G03) Shaft-driven with Stainless Steel pump head



Mono-Block (G03) Shaft-driven with Brass pump head

The Mono-Block pump head combines the valve plate and manifold into one component for servicing without disassembly or removal of plumbing.

G03 Mono-Block Series Performance

Capacities

Flow

Model	Max. Input rpm	Max. Flow @ 69 bar (1000 psi)	
		gpm	l/min
G03-X	1750	3.1	11.7
G03-E	1750	2.2	8.3

Pressure

Maximum Inlet Pressure
17 bar (250 psi)

Maximum Discharge Pressure
69 bar (1000 psi)

Performance and specification ratings apply to G03 Mono-Block configurations unless specifically noted otherwise.

Metering & Dosing

API 675 Performance Characteristics of Steady State Accuracy $\pm 1\%$, Linearity $\pm 3\%$ and Repeatability $\pm 3\%$ can be achieved at speeds up to 1440 rpm and pressures up to 69 bar (metallic pump heads) for X-cam pumps only.

Maximum Flow at Designated Pressure

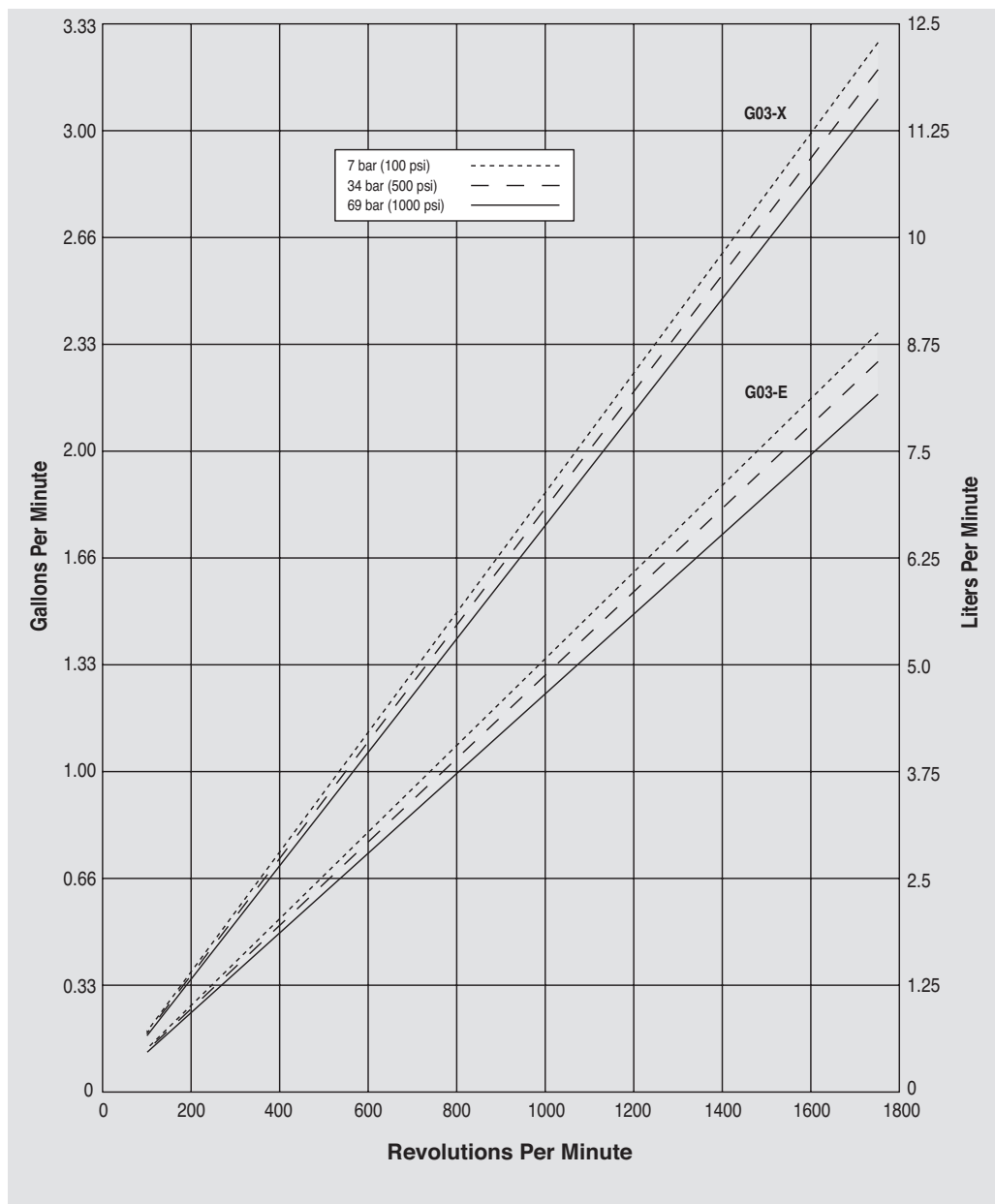

G03 Mono-Block Series Specifications

Flow Capacities @ 69 bar (1000 psi) 4-pole Motor @ 50 Hz

Model	rpm	gpm	l/min
G03-X	1450	2.45	9.3
G03-E	1450	1.80	6.8

Flow Capacities @ 69 bar (1000 psi) 6-pole Motor @ 50 Hz

Model	rpm	gpm	l/min
G03-X	960	1.64	6.2
G03-E	960	1.18	4.5

Delivery @ 69 bar (1000 psi)

Model	gal/rev	liters/rev
G03-X	0.0018	0.0067
G03-E	0.0013	0.0047

Maximum Discharge Pressure

Metallic Heads: 69 bar (1000 psi)

Maximum Inlet Pressure 17 bar (250 psi)

Maximum Operating Temperature

Metallic Heads: 121 °C (250 °F) - Consult factory for correct component selection for temperatures from 71 °C (160 °F) to 121 °C (250 °F).

Maximum Solids Size 200 microns

Inlet Port 1/2 inch BSPT

1/2 inch NPT

Discharge Port 1/2 inch BSPT

1/2 inch NPT

Shaft Diameter G03: 22.22 mm (7/8 inch)

G13: 24mm (0.945 inch) hollow shaft

Shaft Rotation Reverse (bi-directional)

Bearings Precision ball bearings

Oil Capacity 0.95 litres (1.0 US quart)

Weight

Metallic Heads: 12.7 kg (28 lbs.)

Calculating Required Power

$$\frac{6 \times \text{rpm}}{63,000} + \frac{\text{gpm} \times \text{psi}}{1,460} = \text{electric motor hp}$$

$$\frac{6 \times \text{rpm}}{84,428} + \frac{\text{l/min} \times \text{bar}}{511} = \text{electric motor kW}$$

Calculating Pulley Size

$$\frac{\text{motor pulley OD}}{\text{pump rpm}} = \frac{\text{pump pulley OD}}{\text{motor rpm}}$$

When using a variable frequency controller (VFD) calculate the hp or kW at minimum and maximum pump speed to ensure the correct hp or kW motor is selected. Note that motor manufacturers typically de-rate the service factor to 1.0 when operating with a VFD.

Net Positive Suction Head (NPSHr)

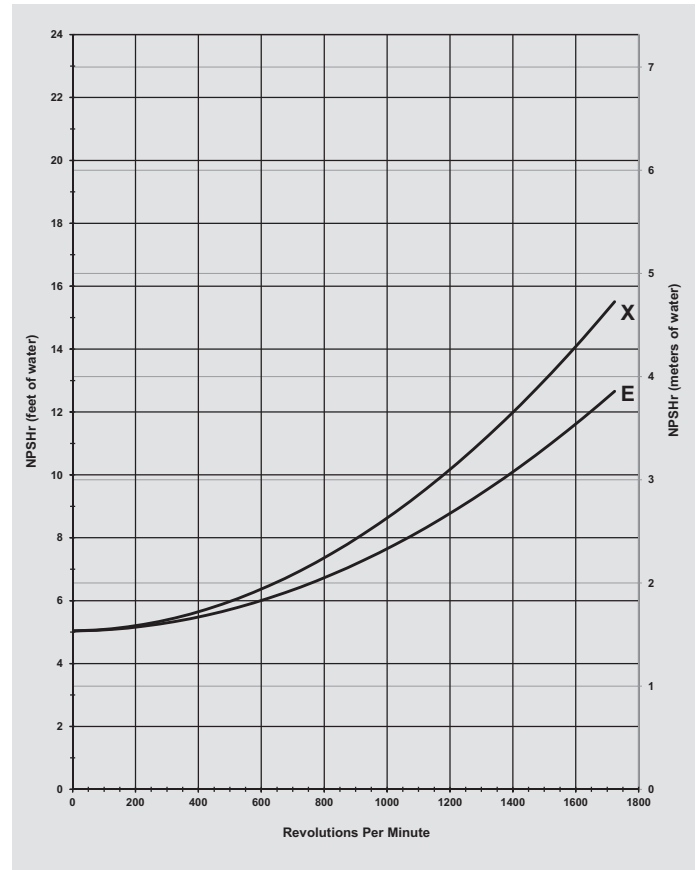

Self-priming:

Each Hydra-Cell pump has different lift capability depending on model size, cam angle, speed, and fluid characteristics. To ensure that your specific lift characteristics are met, refer to the inlet calculations regarding friction, and acceleration head losses in your Hydra-Cell Installation & Service Manual. Compare those calculations to the NPSHr curves above.

G03 Mono-Block Series Representative Drawings

G03 Models with Metallic Pump Head mm (Inches)

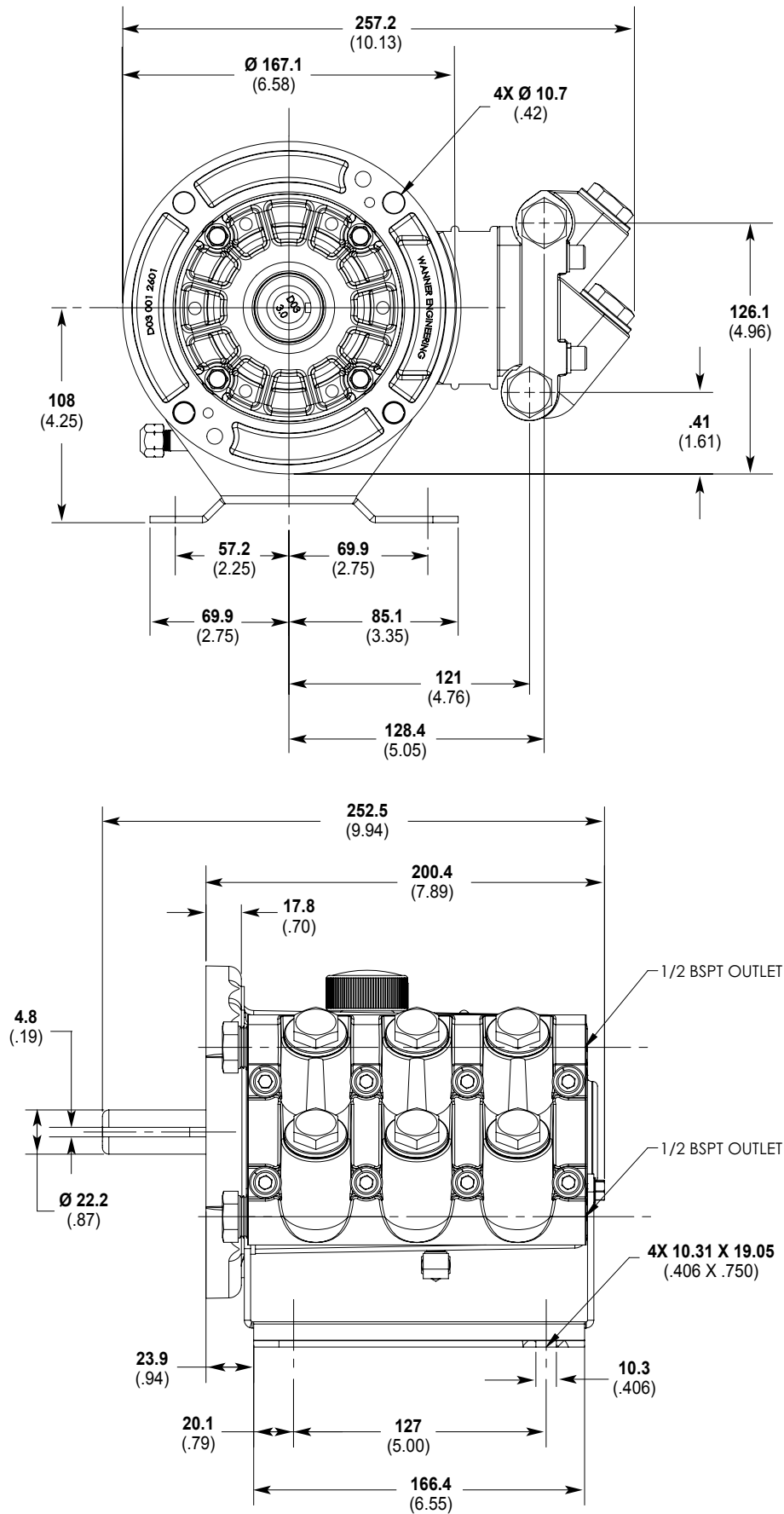

Note: Contact factory for additional drawings of specific models and configurations.

G03 Mono-Block Series Motor Adaptors / Valves

Pump/Motor Adaptor mm (Inches)

Part Number: A04-003-I202

Must be ordered separately for G03 Mono-Block models for use with IEC 80 - 90 frame motors, B5 flange.

NEMA adaptor available - consult factory.

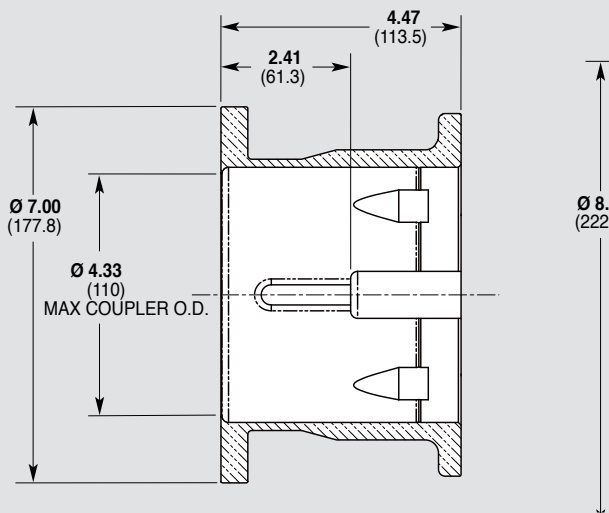

Part Number: A04-004-I202

Must be ordered separately for G03 Mono-Block models for use with IEC 100 - 112 frame motors, B5 flange.

NEMA adaptor available - consult factory.

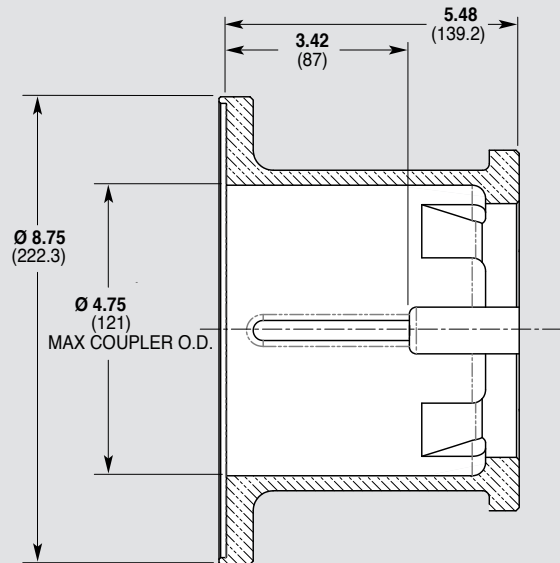

Valve Selection

A Hydra-Cell G03 Mono-Block Series pumping system uses a C46 Pressure Regulating Valve.



G03 Mono-Block Series How to Order

Ordering Information

1	2	3	4	5	6	7	8	9	10	11	12
G		3		M							

A complete G03 Mono-Block Series Model Number contains 12 digits including 9 customer-specified design and materials options, for example: G03EMBPSFEPG.

Digit	Order Code	Description
1-3		Pump Configuration
	G03	Shaft-driven (BSPT Ports)*
	G13	Close-coupled to IEC 90 motor (BSPT Ports)
	-	G13 Option for IEC 80 motor connection (BSPT Ports)
		*Pump/motor adaptors ordered separately. See previous page.
4		Hydraulic End Cam
	X	Max 9.9 l/min (2.6 gpm) @ 1450 rpm
	E	Max 6.8 l/min (1.8 gpm) @ 1450 rpm
5		Pump Head Version
	M	Mono-Block, Kel-Cell (BSPT Ports)
	-	ATEX 2014/34/EU Certified, Category 2, Zone 1, Hazardous Liquids
	-	ATEX 2014/34/EU Certified, Category 2, Zone 1, Non-Hazardous Liquids
	-	ATEX 2014/34/EU Certified, Category 3, Zone 2
		<i>Note: All options include Certificate, Oil Level Monitor or Sight Glass, Earth Stud & Secondary ATEX Label.</i>
6		Pump Head Material
	B	Brass
	S	316L Stainless Steel
7		Diaphragm & O-ring Material
	E	EPDM (requires EPDM-compatible oil - Digit 12 oil code J)
	G	FKM
	J	PTFE
	P	Neoprene
	T	Buna-N
8		Valve Seat Material
	H	17-4 Stainless Steel
	S	316L Stainless Steel
9		Valve Material
	F	17-4 Stainless Steel
	N	Nitronic 50
10		Valve Springs
	E	Elgiloy
	S	316L Stainless Steel

Digit	Order Code	Description
11		Valve Spring Retainers
	M	PVDF
	P	Polypropylene
12		Hydra-Oil
	A	10W30 standard-duty oil
	G	5W30 cold-temp severe-duty synthetic oil
	J	20-wt EPDM-compatible oil
	K	Food-contact oil





WANNER ENGINEERING - WORLD HEADQUARTERS & MANUFACTURING
Minneapolis USA
t: (612) 332-5681
e: sales@wannereng.com

WANNER PUMPS
Kowloon HONG KONG
t: +852 3428 6534
e: sales@wannerpumps.com

WANNER INTERNATIONAL
Hampshire UK
t: +44 (0) 1252 816847
e: sales@wannerint.com

WANNER ENGINEERING
Latin American Office
t: +55 (11) 4081-7098
e: sales@wannereng.com

WANNER PUMPS
Shanghai CHINA
t: +86-21-6876 3700
e: sales@wannerpumps.com